



ART 590 450mm 53LT

GUIDE GRASS - GRASS SLIDES - COULISSES GRASS - GUÍAS GRASS

REV 00.2020

FOIST00030

SIGE S.P.A.

60020 POLVERIGI (AN) ITALY

TEL +39 071 90 90 000 R.A. - FAX +39 071 90 90 804

WWW.SIGE-SPA.IT INFO@SIGE-SPA.IT

PRODOTTO ED ASSEMBLATO IN ITALIA / MADE AND ASSEMBLED IN ITALY / FABRIQUÉ ET ASSEMBLÉ EN ITALIE / HECHO Y MONTADO EN ITALIA

CARATTERISTICHE • FEATURES • CARACTÉRISTIQUES • CARACTERÍSTICAS

Portabiancheria estraibile da 53 Lt. guide estrazione totale maggiorata con soft.

Laundry Bin 53 Lt. Solid base pull-out basket with full extension slides and soft closing.

Corbeille à linge 53 Lt. Panier coulissant à base solide avec glissières pleine extension et fermeture en douceur.

Papelera 53 Lt. Cesto extraíble de base sólida con correderas de extensión completa y cierre suave.

MINUTERIA INTERNA • FITTINGS • FERRURE • FERRETERIA

N°12 3,9x13 Vite autofilettante TC a croce / Self tapping screw TC / Vis autotaraudeuse TC / Tornillo autorroscante TC

N°8 4x16 Vite autofilettante TSP a croce / Self tapping screw TSP / Vis autotaraudeuse TSP / Tornillo autorroscante TSP

N°4 M4x5 Vite cilindrica / Cylindrical screw / Vis cylindrique / Tornillo cilíndrico

N°4 M4x8 Vite cilindrica / Cylindrical screw / Vis cylindrique / Tornillo cilíndrico

N°2 M6x10 Vite / Screw / Vis / Tornillos

N°2 Rondella / Washer / Rondelle / Arandela

COMPONENTI • PARTS • COMPOSANTS • COMPONENTES

A. N°1 Box metallico / Metal box / Boîte en métal / Caja de metal

B. N°1 Coppia carter guide / Kit slide cover / Kit carter pour glissières / Kit carter para las guías

C. N°1 Kit guide Grass / Kit grass slides / Kit glissières grass / Kit de guías grass

D. N°1 Coppia attacco antina / Kit door fixing brackets / Kit de pattes de fixation pour porte / Kit soportes de fijación de la puerta

E. N°4 Tappo / Stopper / Bouchon / Tapón

F. N°1 Secchio 53 Lt. / bin Lt.53 / Poubelle Lt.53 / Cubo Lt.53

G. N°2 Squadretti stabilizzatori antina / Door stabilizing elements

Élément de stabilisation de la porte / Elementos para la estabilización de la puerta

UTENSILERIA • TOOLS • OUTILS • INSTRUMENTOS



MANUTENZIONE • MAINTENANCE • ENTRETIEN • MANTENIMIENTO

Pulire con un panno morbido ed asciutto. Evitare l'uso di solventi e/o abrasivi.

Clean with a soft, dry cloth. Avoid using solvents or abrasive.

Nettoyez avec un chiffon sec et doux. N'utilisez pas aucun solvant ou produit abrasif.

Limpia con paño suave y seco. Evitar el uso de solventes y/o abrasivos.

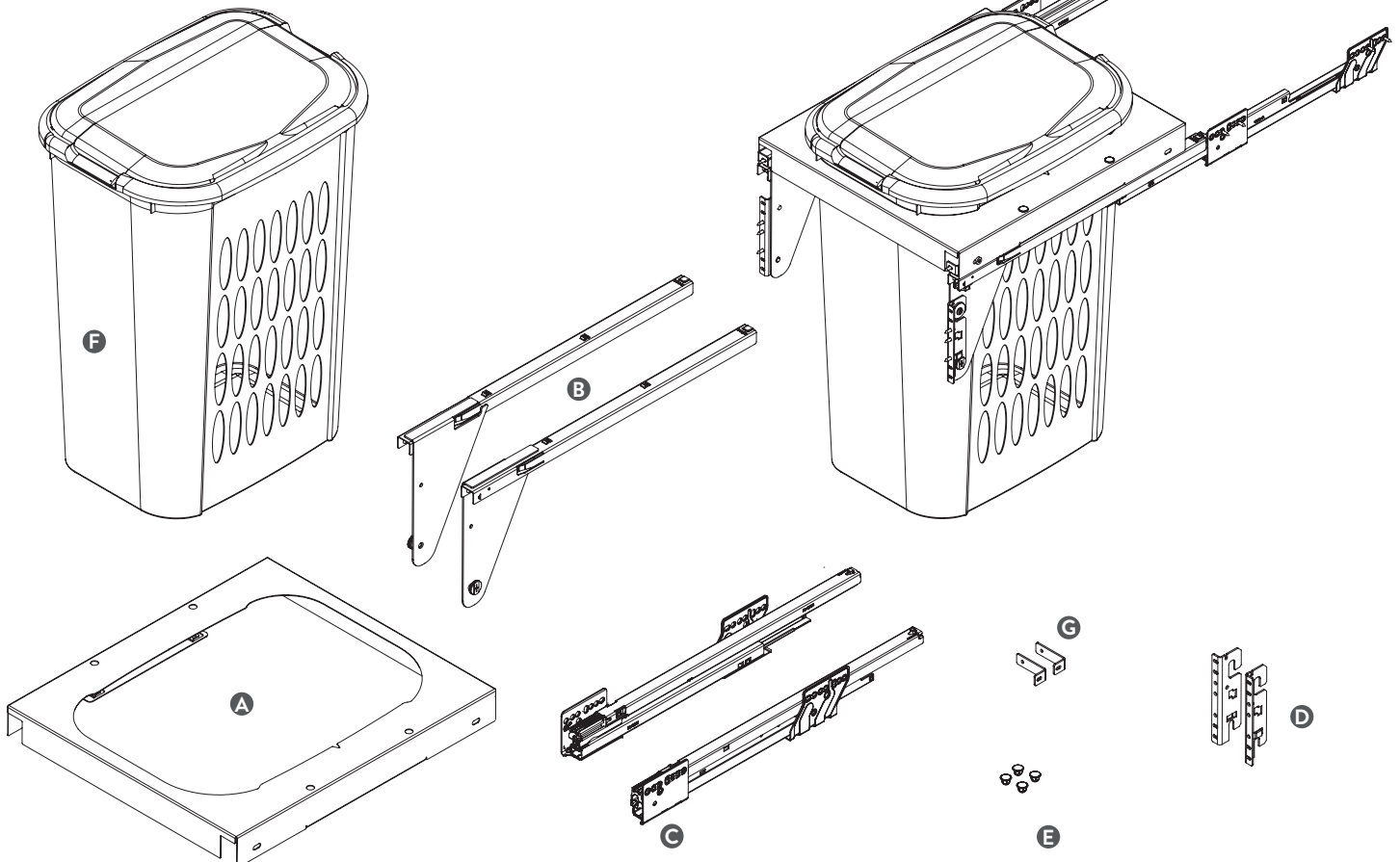
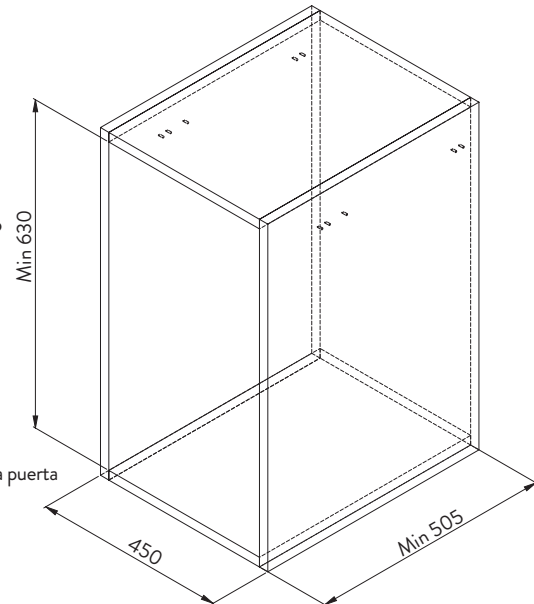

SIGE NON SARÀ RESPONSABILE DI EVENTUALI DANNI OCCORSI PER UTILIZZO DEL PRODOTTO DIFFORME DA QUELLO PER IL QUALE È STATO CONCEPITO. SIGE WILL NOT BE RESPONSIBLE FOR ANY EVENTUAL DAMAGE DUE TO A DIFFERENT USE FROM THE ONE IT HAS BEEN MADE. SIGE NE SERA PAS RESPONSABLE POUR TOUT LES DOMMAGES A CAUSE D'UN DIFFERENT UTILISATION DU PRODUIT POUR LEQUEL IL A ETÉ FABRIQUÉ. SIGE NO SEAR RESPONSABLE PARA CUALQUIER DAÑO DEBIDO AL USO DIFERENTE DE LO POR EL CUAL UN PRODUCTO HA SIDO REALIZADO.

N°8 4x16



1

Fissare le guide C rispettando le quote.
Fix the slides C according to the dimensions.

Fixez le kit glissières C respectant les dimensions.
Fijar el kit de guías C respetando las medidas.

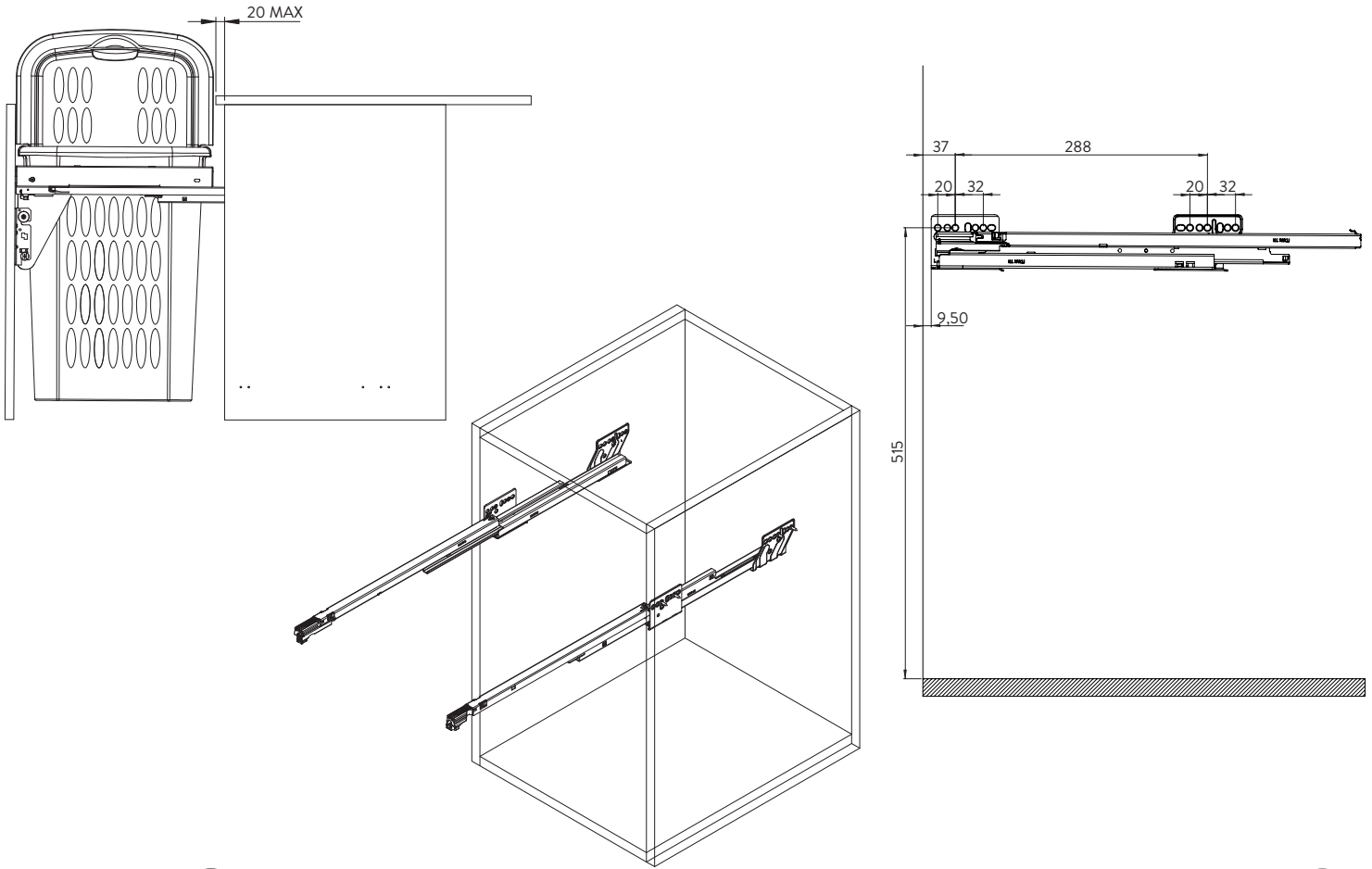

N°8 4x13



2

Fissare la coppia attacco antina D nell'anta, rispettando le quote.
Assemble the kit door fixing brackets D according to the dimensions.
Fixer le kit de pattes de fixation D sur la porte du meuble en respectant les dimensions.
Fijar el kit soportes de fijación de la puerta D en la puerta respetando las medidas.

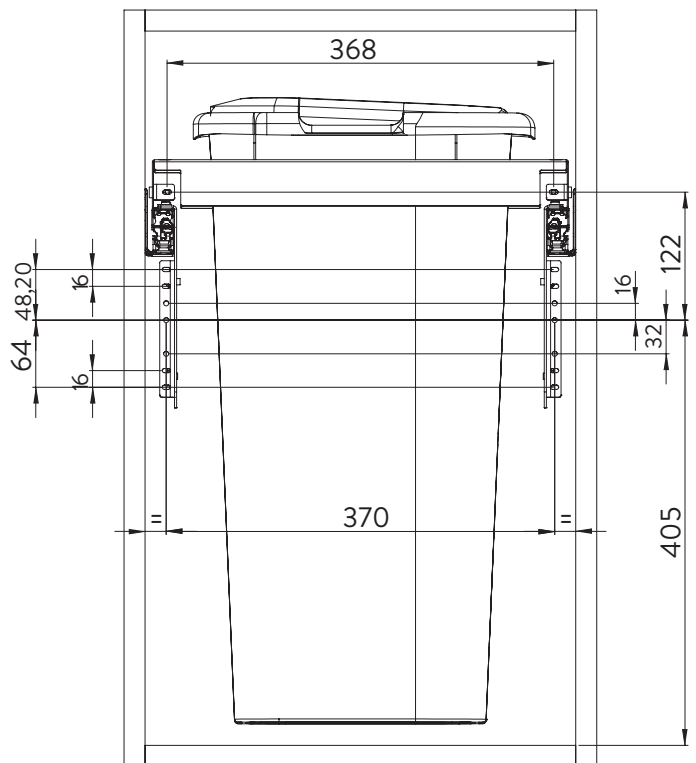
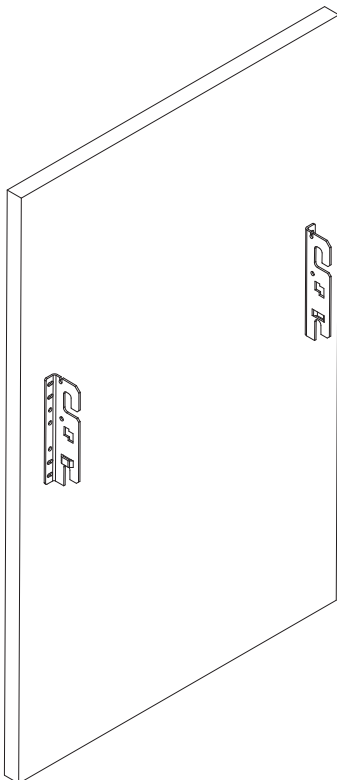

3

Inserire la coppia carter guide B nelle guide C.
Put the kit slide carter B into the Sige slides C.

Insérer le kit carter pour la glissière B dans les glissières C.
Colocar el kit carter para las guías B sobre las guías Sige C.

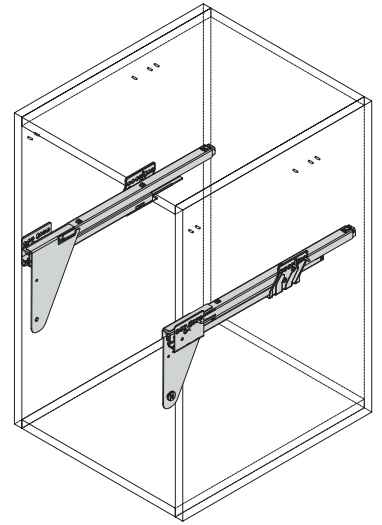
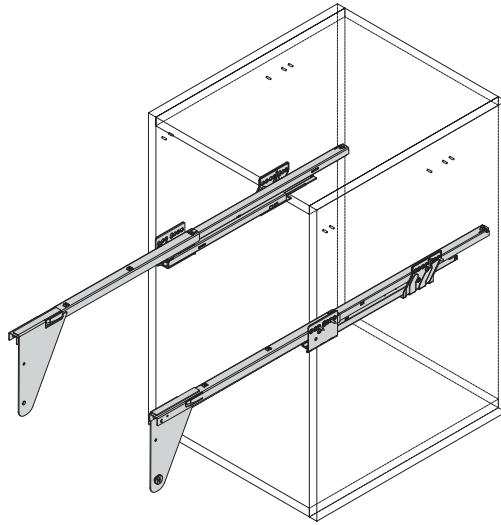
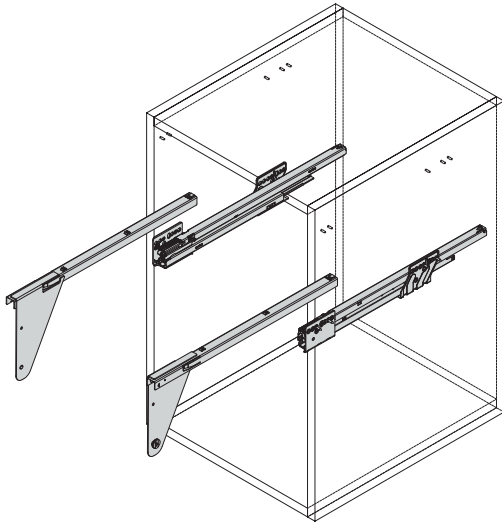
**N°4 M4x5****4**

Sceglere la versione, avvitare il box metallico A nei carter guide B mediante le apposite viti.

Choose the version, screw the metal box A into the kit slide carter B by using the specific provided screws.

Choisissez la version, vissez la boîte en métal A dans le kit carter pour la glissière B avec les spécifiques vis fournies.

Elige la versión, atornillar la caja de metal A en el kit carter para las guías B con los tornillos provistos.

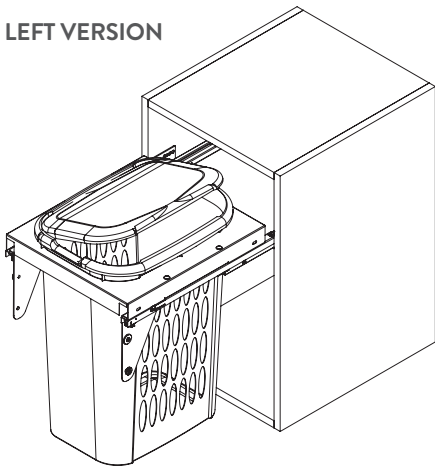
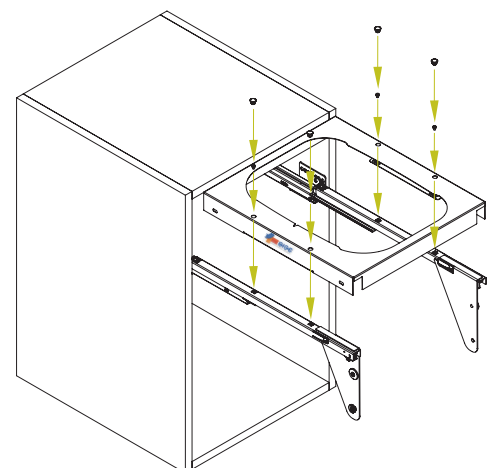
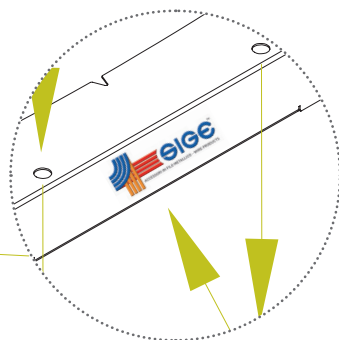
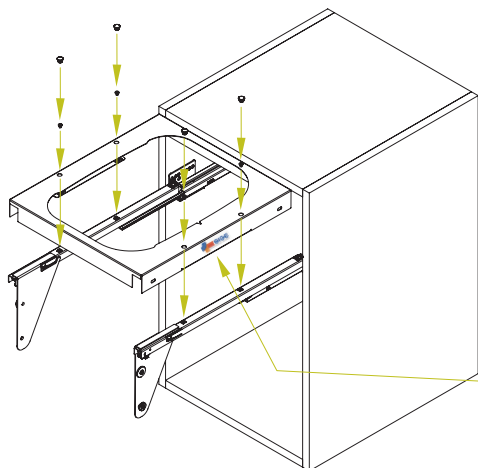
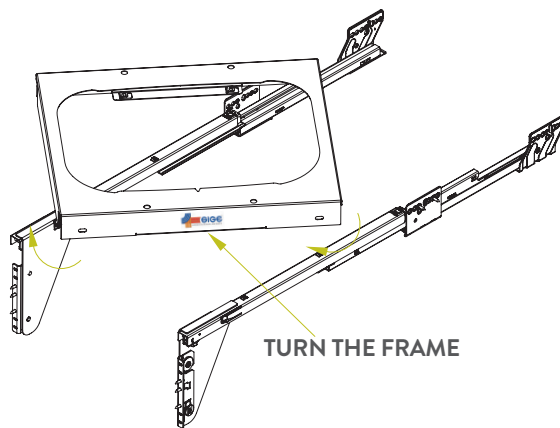
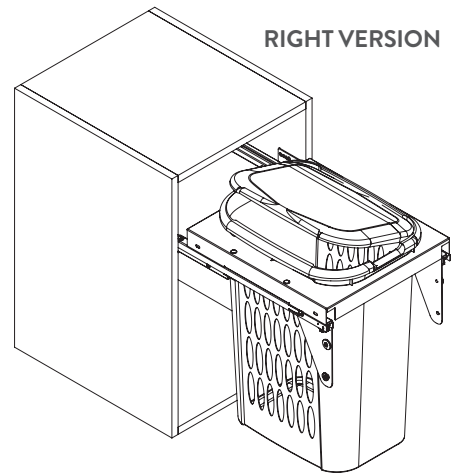
LEFT VERSION**RIGHT VERSION**

N°2 M 5x8



5

Fissare i squadretti stabilizzatori anta G come illustrato dalle foto.
Fix the door stabilising elements G as shown in the pictures.

Fixez les éléments de stabilisation de la porte G comme dans les photo.
Fijar los elementos para la estabilización de la puerta G como se muestra en las imagenes.

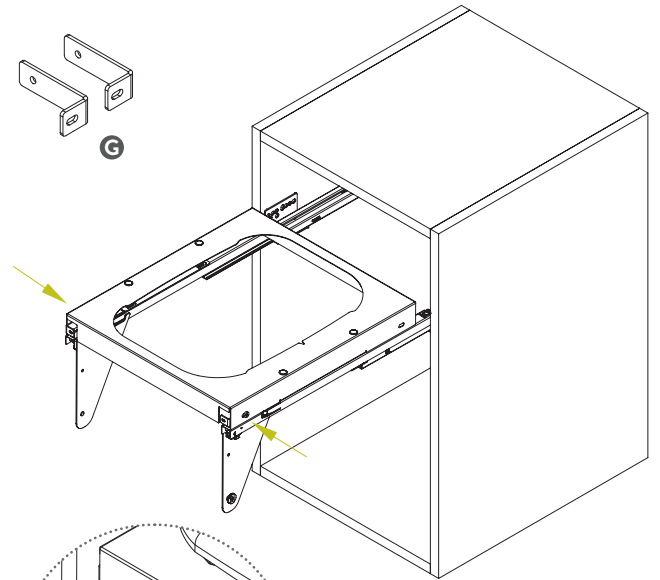
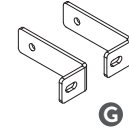
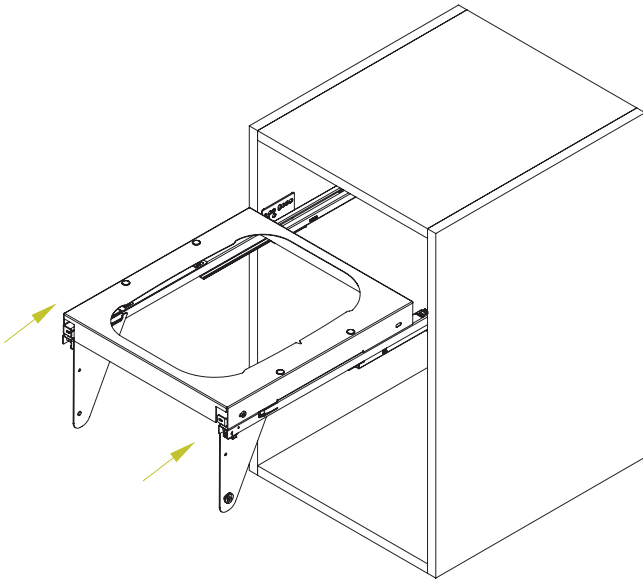

N°2 M6x10



6

Inserire l'antina nei carter B e serrare il tutto a mezzo vite e rondella speciali.

Put the door into the carter B and fix them by using the specific screw and washer.

Insérez le kit carter pour la glissière B et fixez tout avec la vis et la rondelle spécifiques.

Colocar la puerta en los carter B y apretar todo con el tornillo y la arandela específicos.

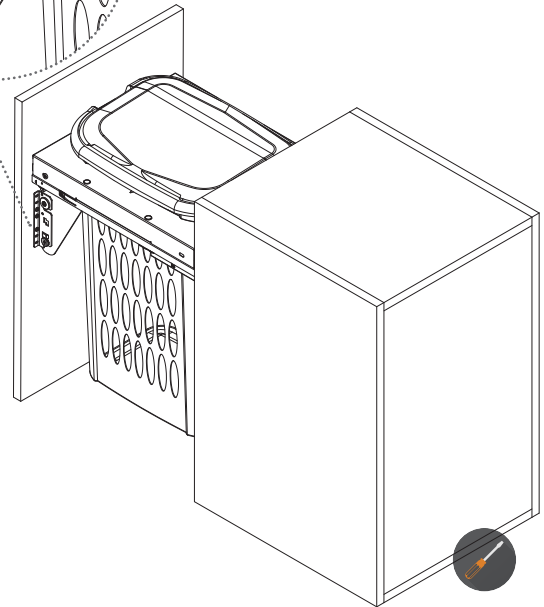
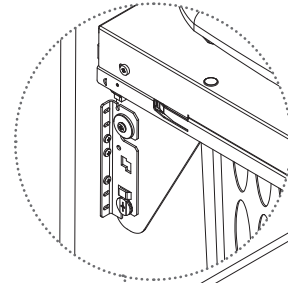
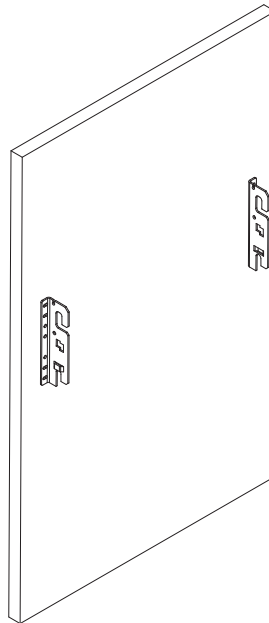

N°2 4x13



7

Effettuare le regolazioni. Fissare le staffe G usando le viti autofilettanti 4x13.
Make adjustments. Fixing brackets D on the door, using 4X13 screws.

Réglez la porte du meuble. Fixation des équerres D sur la porte, à l'aide de vis 4X13.
Ajustar la puerta del mueble. Fijación de los soportes D en la puerta, mediante tornillos 4X13.

