



ART 094C

SIGE S.P.A.
60020 POLVERIGI (AN) ITALY
TEL +39 071 90 90 000 R.A. - FAX +39 071 90 90 804
WWW.SIGE-SPA.IT INFO@SIGE-SPA.IT

REV 00.2023
FOIST00188

PRODOTTO ED ASSEMBLATO IN ITALIA / MADE AND ASSEMBLED IN ITALY / FABRIQUÉ ET ASSEMBLÉ EN ITALIE / HECHO Y MONTADO EN ITALIA

CARATTERISTICHE • FEATURES • CARACTÉRISTIQUES • CARACTERÍSTICAS

Cestello multifunzione "Idea" in lamiera verniciata.
Multipurpose basket "Idea" with painted metal sheet sides.
Panier multifonctions "Idea" avec côtés en tôle peinte.
Cesta multiuso "Idea" con laterales de chapa pintada.

MINUTERIA INTERNA • FITTINGS • FERRURE • FERRETERIA

N10 4x16 Vite autofilettante / Self tapping screw / Vis autotaraudeuse / Tornillos autorroscantes
N°2 M4x8 Viti / Screw / Vis / Tornillos

COMPONENTI • PARTS • COMPOSANTS • COMPONENTES

- A. N°1 094C Telaio / Frame / chassis / chasis
- B. N°1 Attacco antina superiore / Top door fixing bracket / Support de fixation de porte supérieure / Soporte de fijación de puerta superior
- C. N°1 Cover attacco antina superiore / Top door fixing cover / Couverture pour la patte de fixation supérieure / Cobertura para los soportes de fijación superior
- D. N°1 Cover posteriore telaio / Frame back cover / Uverture pour la patte de fixation supérieure / Cobertura para los soportes de fijación superior
- E. N°1 Kit vaschetta porta mestoli / Kit spoon holder bucket / Kit seau porte-cuillère / Kit cuchara porta cuchara
- F. N°1 Kit vaschetta porta coltelli / Kit knife holder bucket / Kit seau porte-couteau / Kit cuchillo porta cuchillos
- G. N°1 Kit vaschetta porta spezie / Kit spice holder bucket / Kit seau porte-épices / Kit cubo porta especias
- H. N°1 Vaschetta ad aggancio / Hanging bucket / Seau suspendu / Cubo colgando
- I. N°2 Cover fondo / Bottom cover / Couvercle inférieur / Cubierta inferior

UTENSILERIA • TOOLS • OUTILS • INSTRUMENTOS



MANUTENZIONE • MAINTENANCE • ENTRETIEN • MANTENIMIENTO

Pulire con un panno morbido ed asciutto. Evitare l'uso di solventi e/o abrasivi.
Clean with a soft, dry cloth. Avoid using solvents or abrasive.
Nettoyez avec un chiffon sec et doux. N'utilisez pas aucun solvant ou produit abrasif.
Limpiar con paño suave y seco. Evitar el uso de solventes y/o abrasivos.

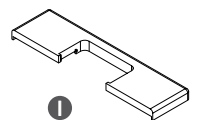
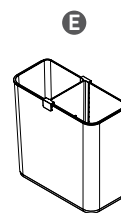
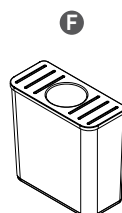
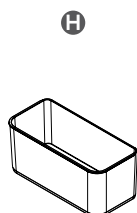
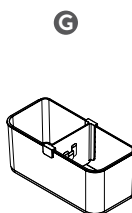
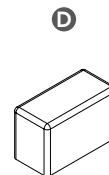
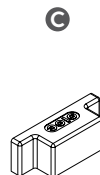
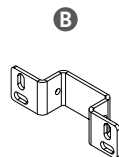
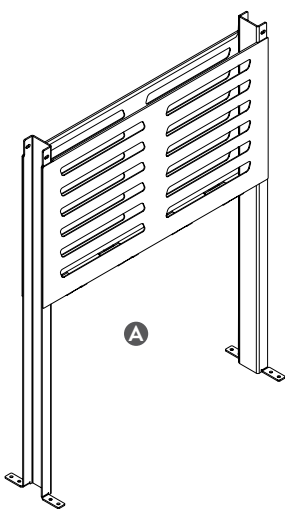
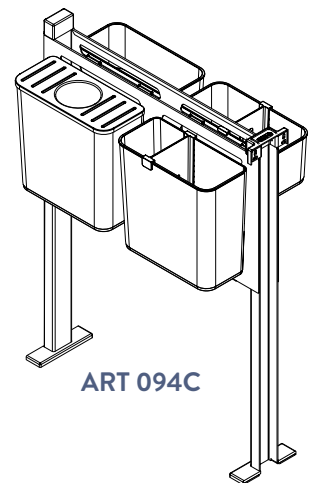
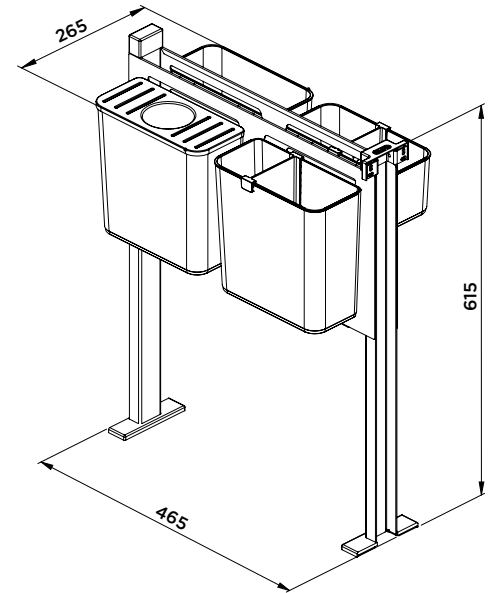

N°8 4x16



1

Posizionare il telaio (A), avvitarlo con le apposite viti ed inserire il cover posteriore (D).
Position the frame (A), screw it with the appropriate screws and insert the back cover (D).
Positionnez le cadre (A), vissez-le avec les vis appropriées et insérez le couvercle arrière (D).
Coloque el marco (A), atorníllelo con los tornillos adecuados e inserte la tapa trasera (D).

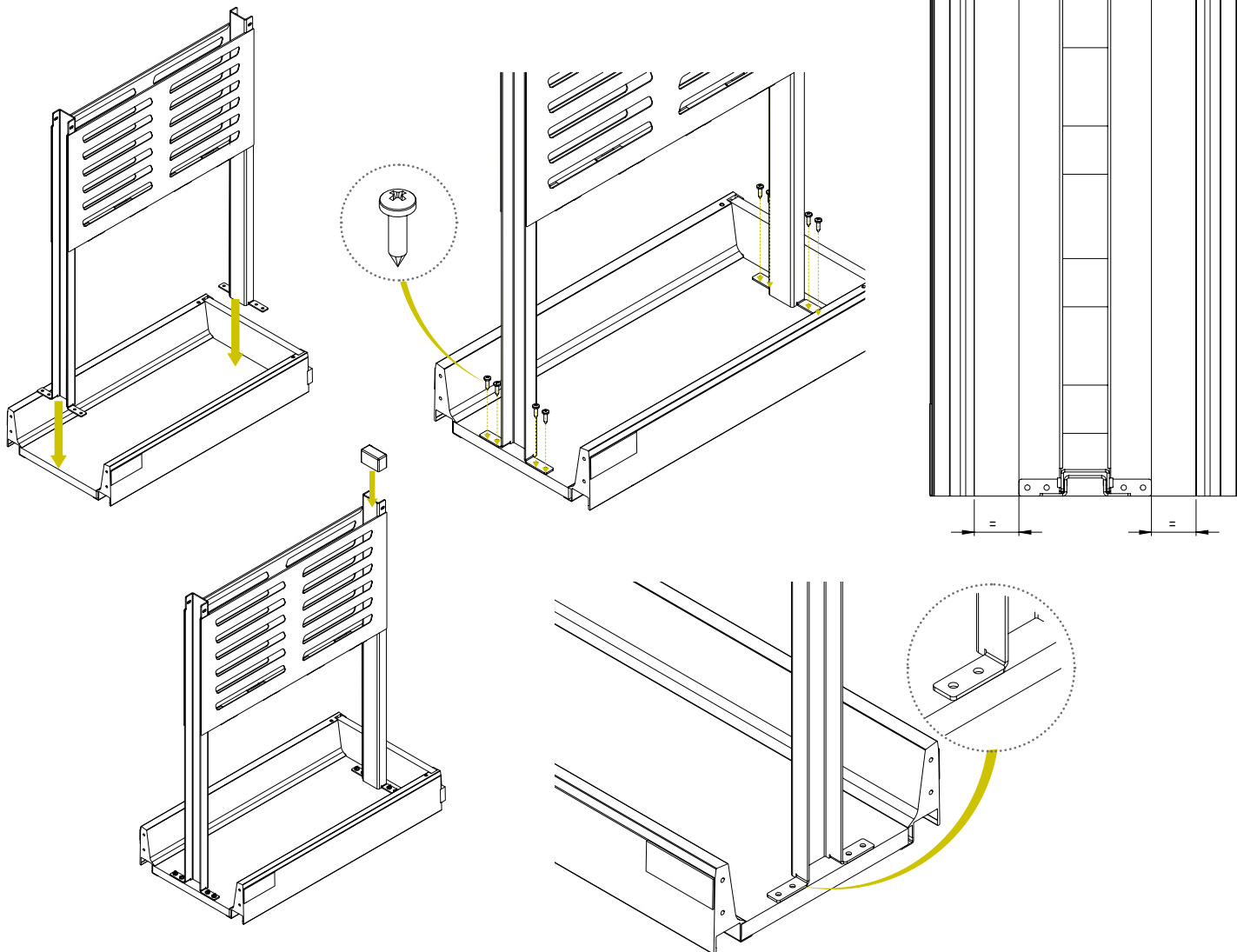

N°2 M4x8



2

Posizionare il cassetto all'interno del mobile ed avvitare l'attacco antina (B) senza serrare le viti.
Position the drawer inside the cabinet and screw the door attachment (B) without tightening the screws.
Positionner le tiroir à l'intérieur du meuble et visser la fixation de porte (B) sans serrer les vis.
Coloque el cajón dentro del gabinete y atornille el accesorio de la puerta (B) sin apretar los tornillos.

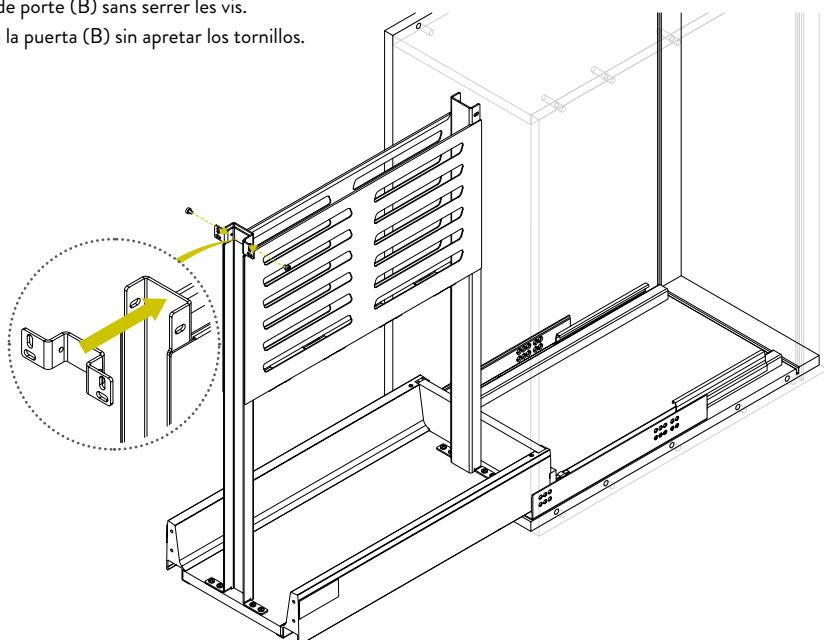

N°2 4x16



3

Agganciare l'anta alle sponde del cassetto ed avvitare l'attacco antina precedentemente montato.
Hook the door to the drawer sides and screw the previously assembled door attachment.
Accrochez la porte aux côtés du tiroir et vissez la fixation de porte précédemment assemblée.
Enganche la puerta a los lados del cajón y atornille el accesorio de puerta previamente ensamblado.

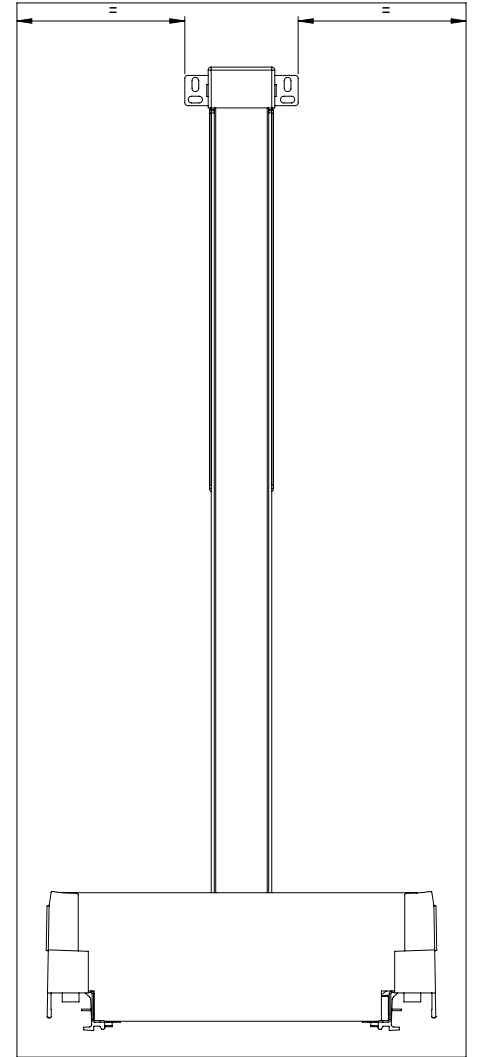
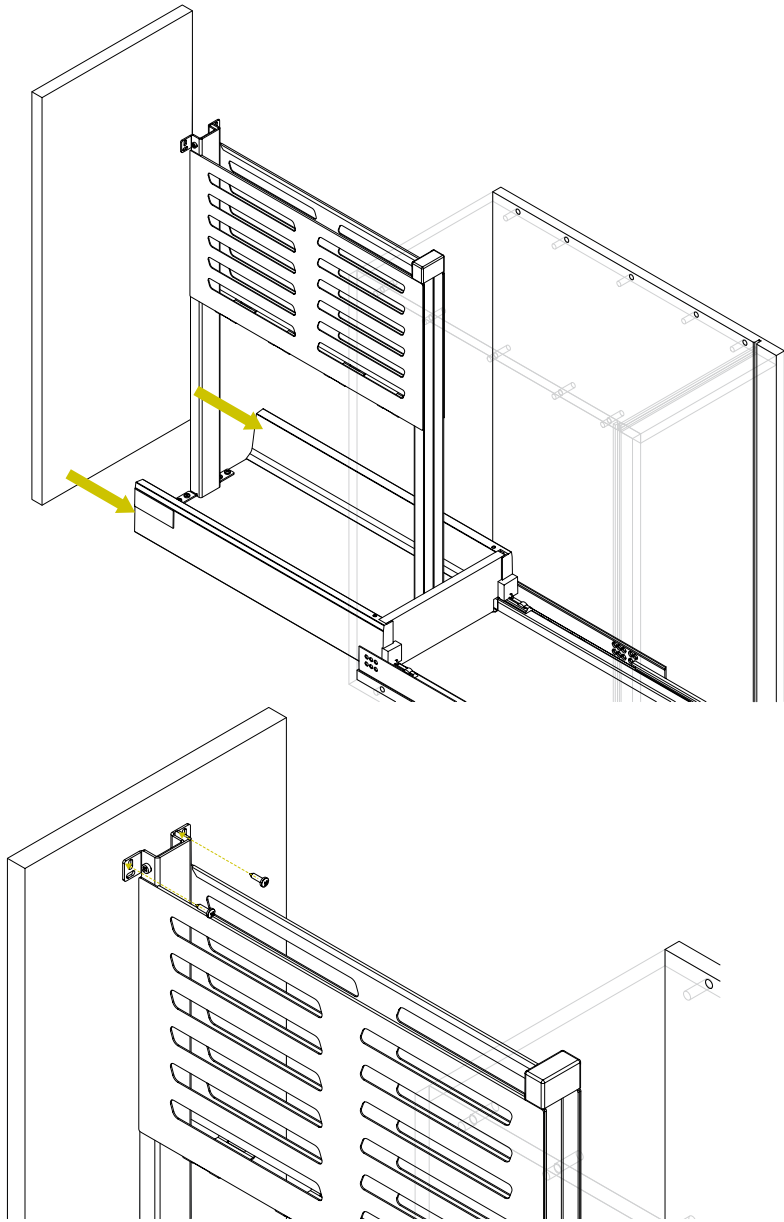

Dopo aver avvitato l'attacco antina, regolare l'inclinazione e serrare le viti.
After having screwed the door attachment, adjust the inclination and tighten the screws.
Après avoir vissé la fixation de la porte, régler l'inclinaison et serrer les vis.
Después de haber atornillado el enganche de la puerta, regule la inclinación y apriete los tornillos.

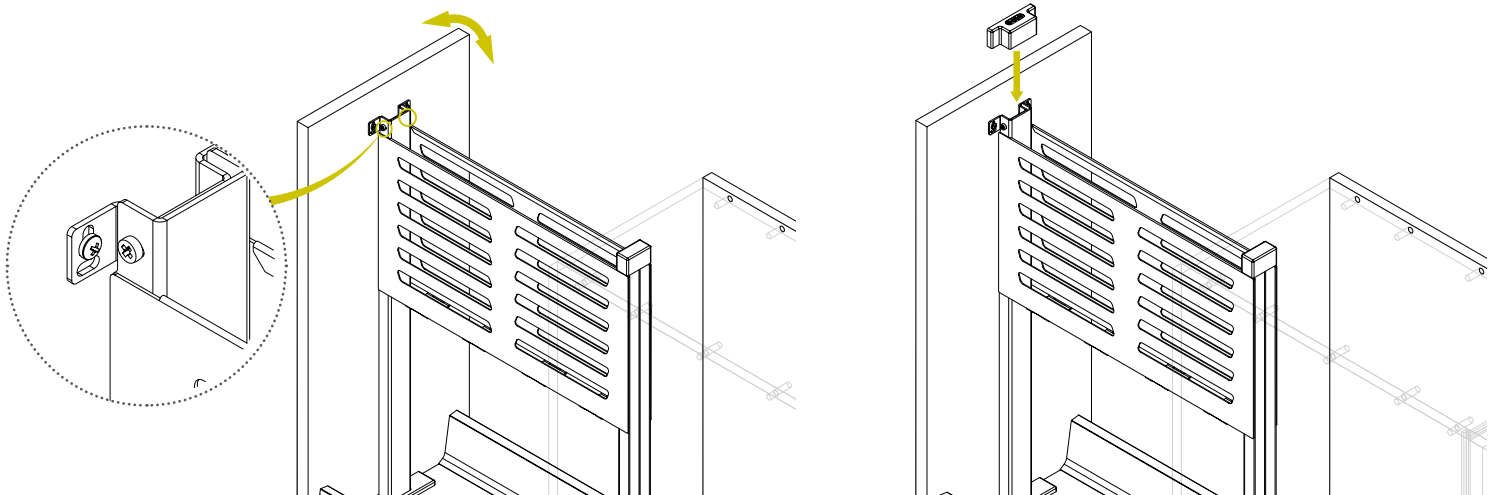

4

Montare i cover inferiori e le vaschette.

Fit the bottom covers and trays.

Monter les couvercles inférieurs et les plateaux.

Coloque las tapas inferiores y las bandejas.

