



ART 004M H685 ART 004ME H685

GUIDE SIGE - SIGE SLIDES - COULISSES SIGE - GUIAS SIGE

REV 00.2024

FOIST00407

SIGE S.P.A.

60020 POLVERIGI (AN) ITALY

TEL +39 071 90 90 000 R.A. - FAX +39 071 90 90 804

WWW.SIGE-SPA.IT INFO@SIGE-SPA.IT

PRODOTTO ED ASSEMBLATO IN ITALIA / MADE AND ASSEMBLED IN ITALY / FABRIQUÉ ET ASSEMBLÉ EN ITALIE / HECHO Y MONTADO EN ITALIA

CARATTERISTICHE • FEATURES • CARACTÉRISTIQUES • CARACTERÍSTICAS

Cestello jolly con fondo in nobilitato e guide ad estrazione totale con soft.
Solid base pull-out basket with full extension slides and soft closing.
Panier bas coulissant avec coulisses sortie-totale et soft closing. Panier fond mélaminé.
Cesto jolly en asiento laminado con guias a estracción total con soft.

MINUTERIA INTERNA • FITTINGS • FERRURE • FORRETERIA

N°14 4x16 Vite autofilettante / Self tapping screw / Vis autotaraudeuse / Tornillos autorroscantes

N°4 6,3x12 Eurovite / Eurovite / Eurovite / Eurovite

N°4 M5x10 Viti / Screw / Vis / Tornillos

N°8 3,9x13 Vite autofilettante / Self tapping screw / Vis autotaraudeuse / Tornillos autorroscantes

COMPONENTI • PARTS • COMPOSANTS • COMPONENTES

A. N°1 004M H685 Cestello / Basket / Panier / Cesto

B. N°1 004ME H685 Cestello / Basket / Panier / Cesto

C. N°1 Set guide / Set slides / Kit coulisses / Set de guias

D. N°4 Staffe fissaggio antina / Door brackets / Pattes fixation porte / Escuadras para ajuste de puerta

E. N°2 Carter per guide / Slides carter / Carter coulisses / Carter para guias

F. N°1 Set spessori fianchi mobile da 18/20 mm / Cabinet side thickness spacer kit 18/20 mm

Set d'épaisseur pour cotés des meubles 18/20 mm / Set de espesores para costados del mueble 18/20 mm

G. N°1 Set spessori fianchi mobile da 16/19 mm / Cabinet side thickness spacer kit 16/19 mm

Set de espesores para costados del mueble 16/19 mm / Kit espesores lados del mueble 16/19 mm

H. N°2 Cover attacco antina / Door fixing cover / Coverture pour la patte de fixation / Cobertura para los soportes de fijación

I. N°4 Sponda / Insert / Insert / Lateral

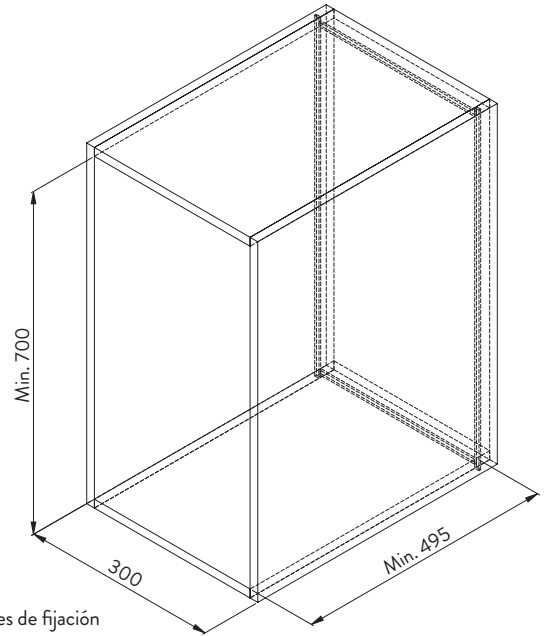

UTENSILERIA • TOOLS • OUTILS • INSTRUMENTOS



MANUTENZIONE • MAINTENANCE • ENTRETIEN • MANTENIMIENTO

Pulire con un panno morbido ed asciutto. Evitare l'uso di solventi e/o abrasivi.

Clean with a soft, dry cloth. Avoid using solvents or abrasive.

Nettoyez avec un chiffon sec et doux. N'utilisez pas aucun solvant ou produit abrasif.

Limpia con paño suave y seco. Evitar el uso de solventes y/o abrasivos.

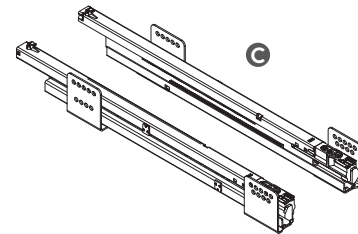

ART 004M H685

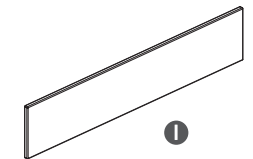
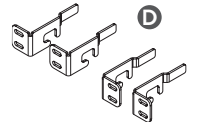

ART 004ME H685

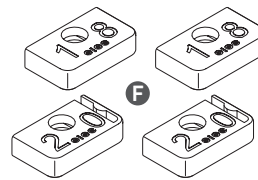
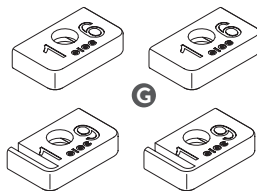
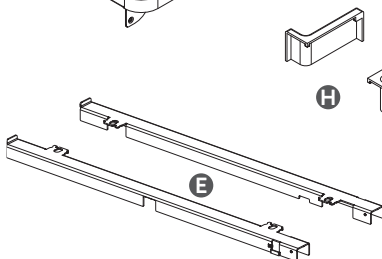
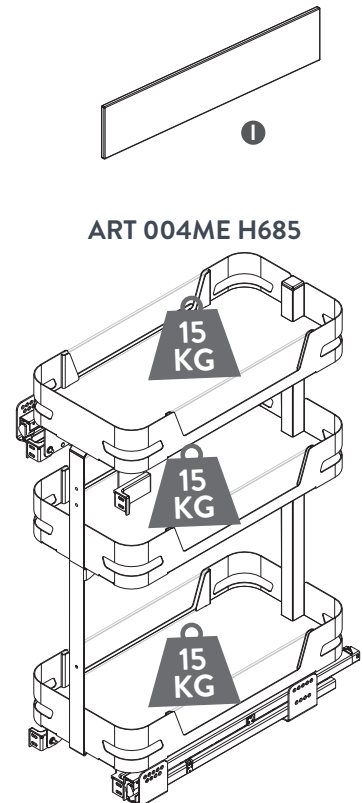
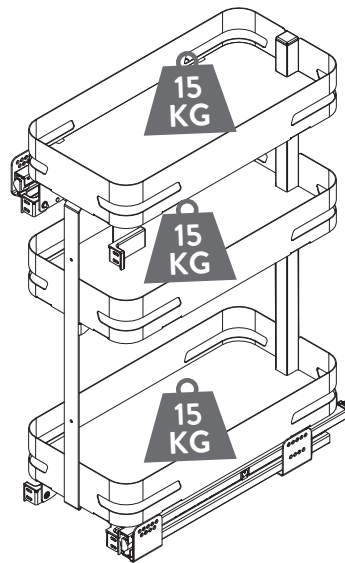
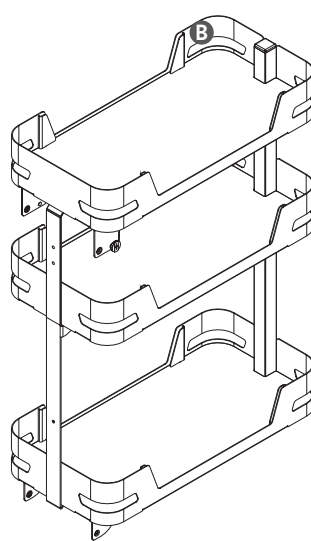
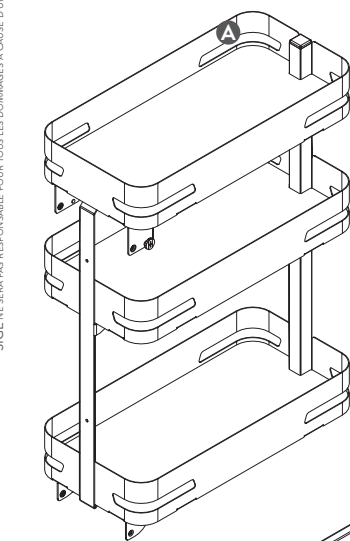

N°8 4x16



1

Posizionare le guide C rispettando le quote indicate ed avvitarle con le apposite viti sui fianchi del mobile.

Place slides C respecting showed data and screw them on the cabinet's sides.

Positionez les coulisses C en respectant les mesures indiquées et serrez les vis sur les côtés du meuble.

Posicionar las guías C respetando las medidas indicadas y atornillar con sus debidos tornillos sobre los costados del mueble.

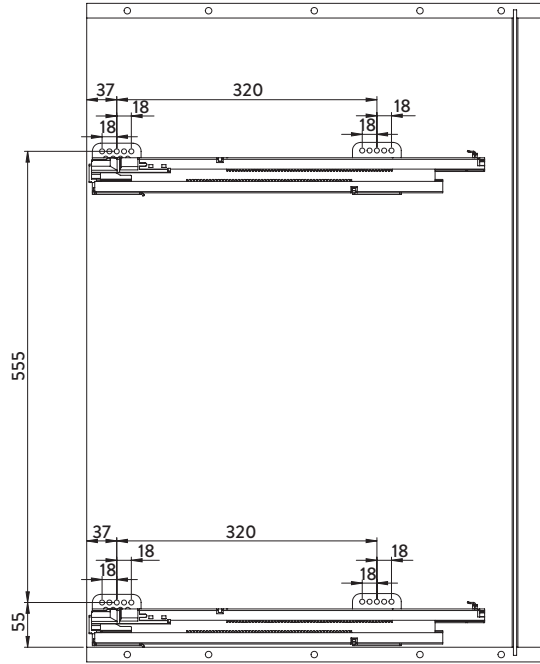
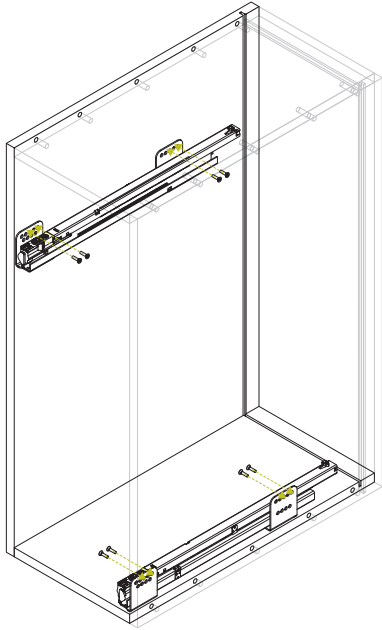

N°8 3,9x13



2

Avvitare le staffe D sull'antina rispettando le misure indicate.

Screw D brackets on the door respecting showed data.

Vissez les pattes D sur la porte en respectant les mesures indiquées.

Atornillar los soportes D sobre la puerta respetando las medidas indicadas.

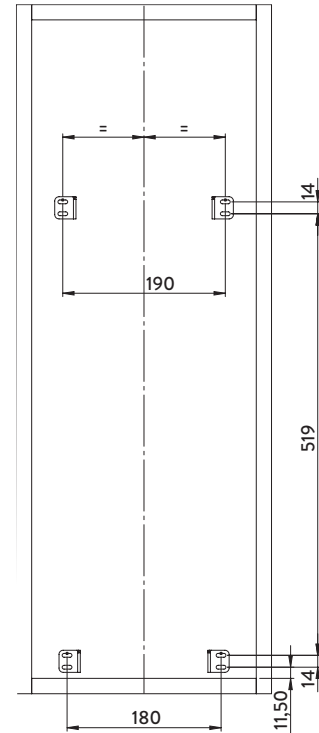
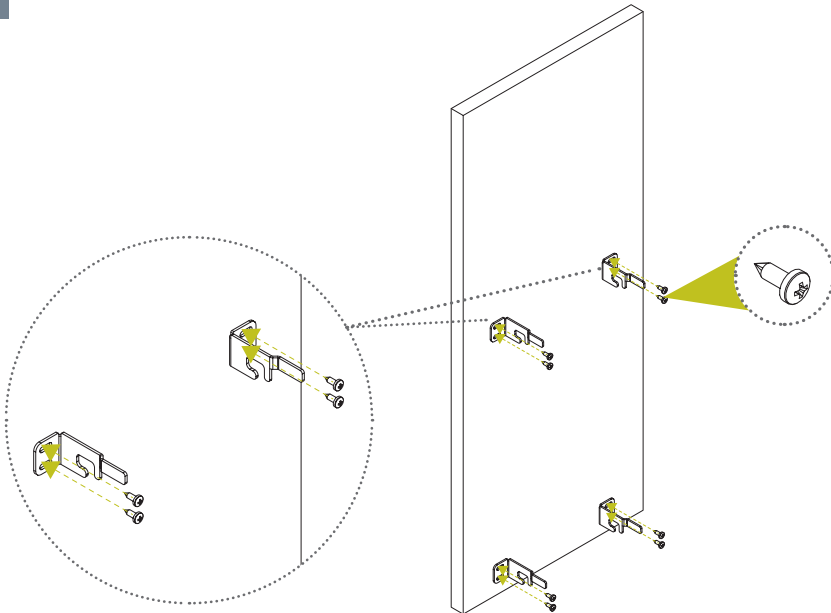

3

Scegliere i particolari F o G a seconda dello spessore fianco mobile, come mostrato nella tabella*, Inserire i particolari nel carter E.

Choose the F or G part depending on the cabinet side thickness, as shown in the table*, Insert the parts in the carter E.

Choisissez les particuliers F ou G en fonction de l'épaisseur du flanc mobile, comme indiqué dans le tableau *, insérer les particuliers dans le carter E.

Elija los componentes F o G segundo el grosor del lado del mueble, como se muestra en la tabla *, inserte llos componentes en el carter E.

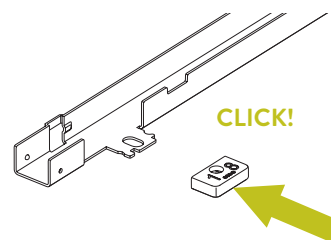

ES. SIDE 18MM

*	SPESSORE FIANCO MOBILE CABINET SIDE THICKNESS	COMPONENTE PART
	18mm	F
	20mm	
	16mm	G
	19mm	

4**N°4 M5x10 N°4 6,3x12**

Avvitare i carter E sul pianetto tramite le euroviti 6,3x12. Premontare le quattro viti M5x12.
 Screw the carter E onto the shelf using the 6,3x12 eurovites. Pre-assemble the four M5x12 screws.
 Visser le carter E sur l'étagère en utilisant les eurovites 6,3x12. Pré-assembler les quatre vis M5x12.
 Atornille el carter E en el estante usando los eurovites 6,3x12. Premontar los cuatro tornillos M5x12.

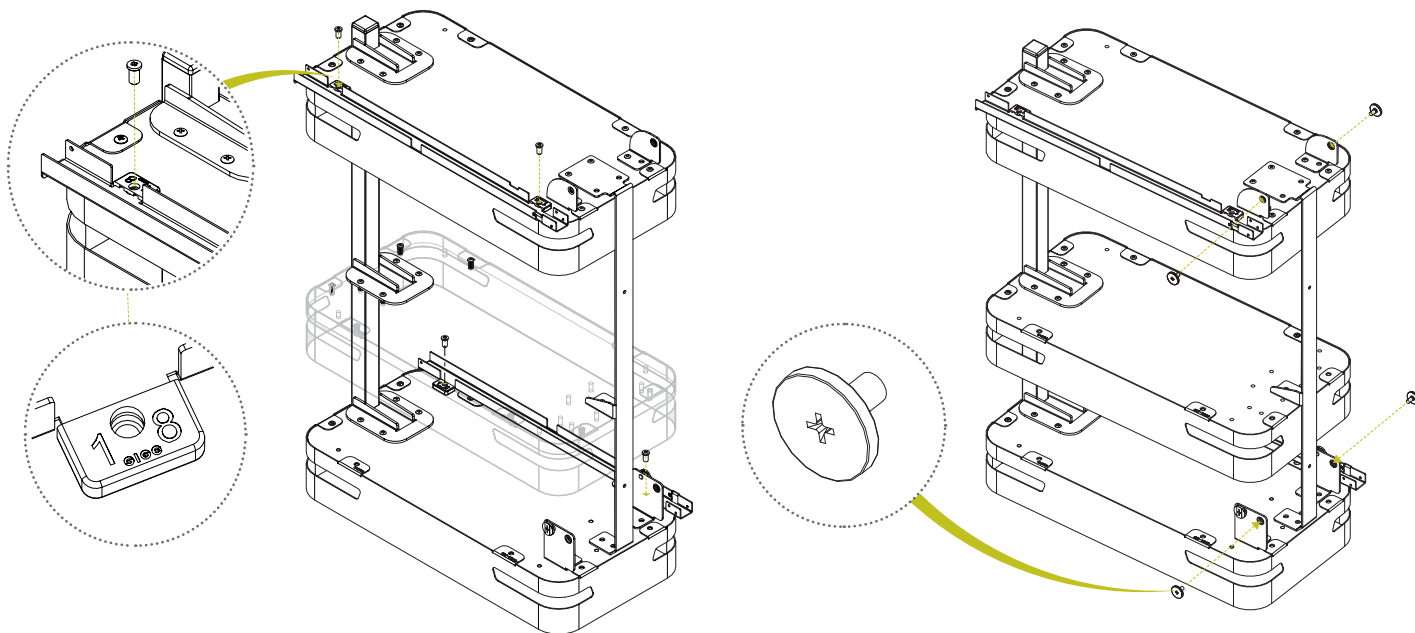
**5**

Montare il cesto A o B sulle guide C.
 Fit basket A or B on slides C.
 Monter le panier A ou B sur les coulisses C.
 Montar el cesto A o B sobre las guías C.

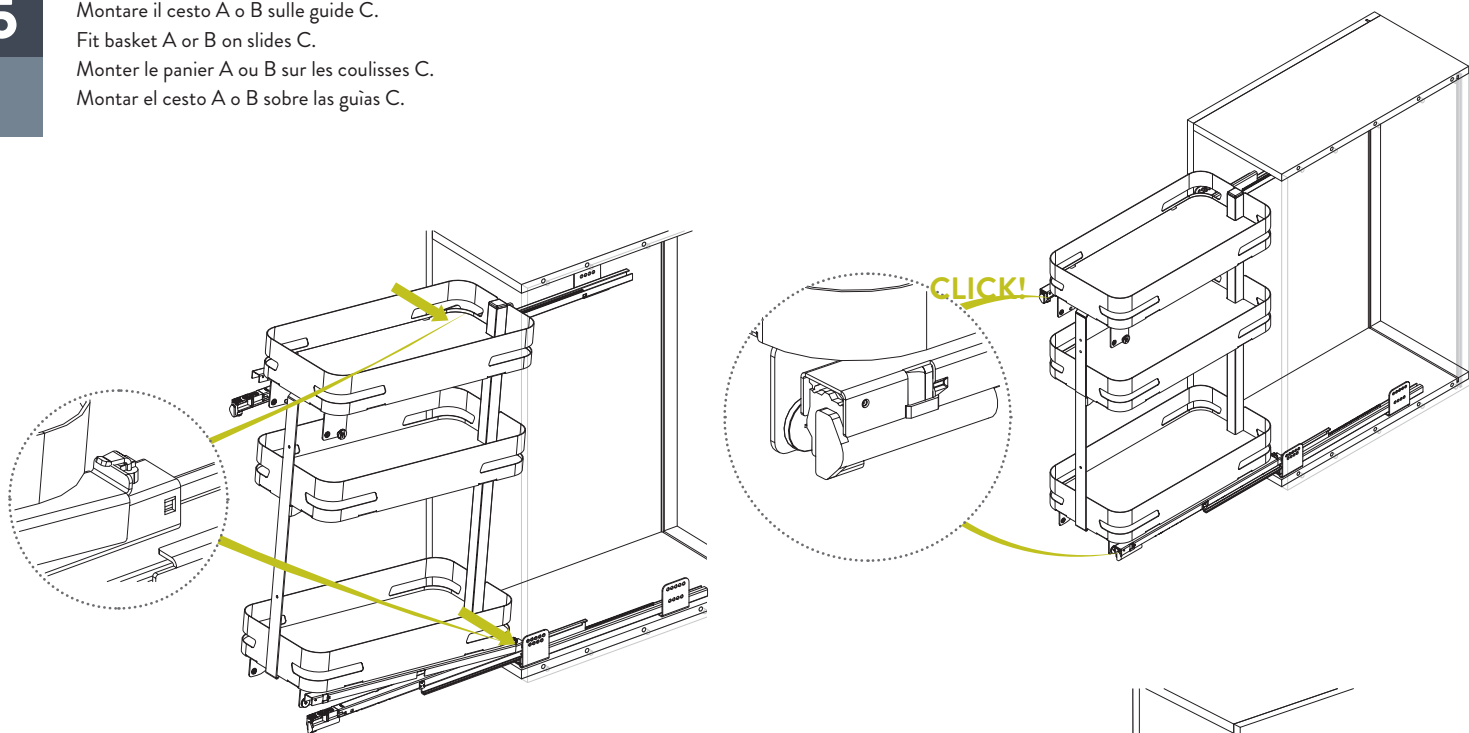
**6**

Montare l'antina sul cesto A o B e serrare le quattro viti M5x12.
 Fix the door on the basket A or B and tighten the four M5x12 screws.
 Fixez la porte sur le panier A ou B et serrez les quatre vis M5x12.
 Fije la puerta en la cesta A o B y apriete los cuatro tornillos M5x12.

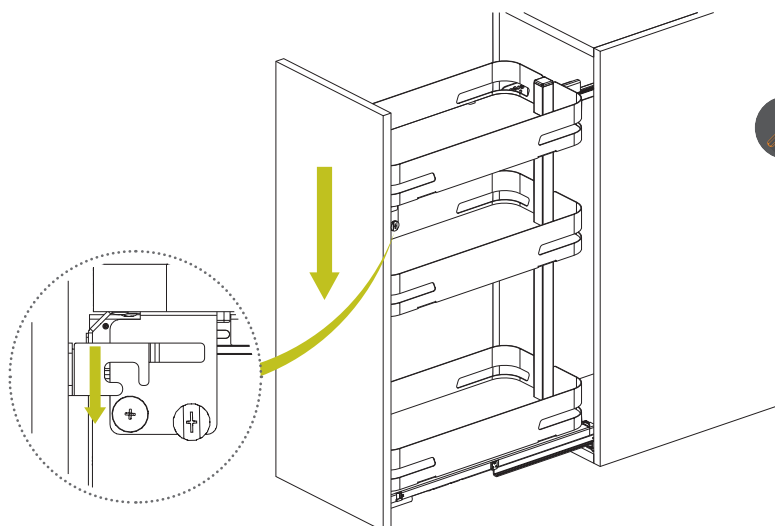



7

Allentare le quattro M5x12 (a), girare la vite (b) come mostrato per regolare l'antina in su e giù.
 Loosen the four M5x12 (a), turn the screw (b) as shown to adjust the door up and down.
 Desserrez les quatre M5x12 (a), tournez la vis (b) comme indiqué pour ajuster la porte de haut en bas.
 Afloje los cuatro M5x12 (a), gire el tornillo (b) como se muestra para ajustar la puerta hacia arriba y hacia abajo.

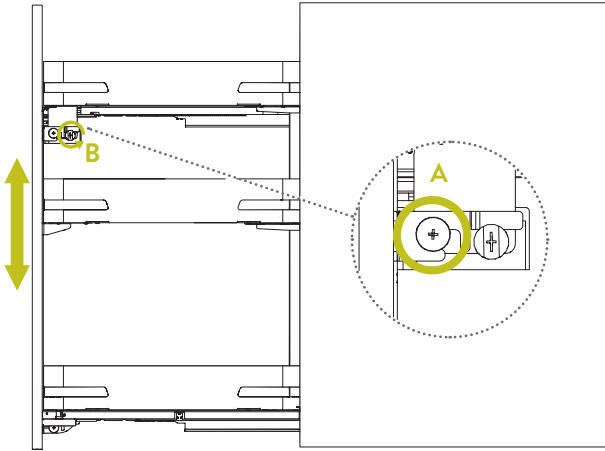

8

Allentare le quattro M5x12, per regolare l'antina in avanti ed in dietro.
 Loosen the four M5x12, to adjust the door forward and back.
 Desserrez les quatre M5x12, pour ajuster la porte avant et arrière.
 Afloje los cuatro M5x12, para ajustar la puerta hacia adelante y hacia atrás.

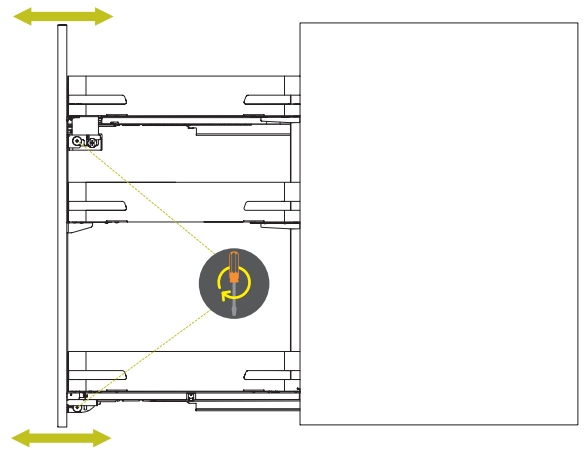

9

Allentare le otto 3,9x13, per regolare l'antina a destra e sinistra.
 Loosen the eight 3,9x13, to adjust the door to the right and left.
 Desserrez les huit 3,9x13, pour ajuster la porte à droite et à gauche.
 Afloje los ocho 3,9x13, para ajustar la puerta a la derecha e izquierda.

