



# ART 116PRO

GUIDE SIGE - SIGE SLIDES - COULISSES SIGE - GUÍAS SIGE

REV 00.2020

FOIST00153

SIGE S.P.A.

60020 POLVERIGI (AN) ITALY

TEL +39 071 90 90 000 R.A. - FAX +39 071 90 90 804

WWW.SIGE-SPA.IT INFO@SIGE-SPA.IT

PRODOTTO ED ASSEMBLATO IN ITALIA / MADE AND ASSEMBLED IN ITALY / FABRIQUÉ ET ASSEMBLÉ EN ITALIE / HECHO Y MONTADO EN ITALIA

## CARATTERISTICHE • FEATURES • CARACTÉRISTIQUES • CARACTERÍSTICAS

Cassetto estraibile in lamiera con guide ad estrazione totale e chiusura ammortizzata.

Pull out metal drawer, full extension slides with soft closing.

Tiroir coulissant en tôle avec glissières sortie totale et amortisseur.

Cajón extraíble en chapa con guías de extracción total y amortiguador.

## MINUTERIA INTERNA • FITTINGS • FERRURE • FERRETERIA

N°8 3,9x13 Vite autofilettante TC a croce / Self tapping screw TC

Vis autotaraudeuse TC / Tornillo autorroscante TC

N°12 4x16 Vite autofilettante TSP a croce / Self tapping screw TSP

Vis autotaraudeuse TSP / Tornillo autorroscante TSP

## COMPONENTI • PARTS • COMPOSANTS • COMPONENTES

A. N°1 Cesto / Basket / Panier / Cesta

B. N°1 Set guide Sige / Sige slides kit / Kit coulisses Sige / Kit guías Sige

C. N°4 Distanziali 2mm / Spacers 2mm / Entretoises 2mm / Distanciadores 2mm

D. N°1 Coppia attacco antina / Door fixing brackets kit

Kit de pattes de fixation pour porte / Kit soportes de fijación a la puerta

E. N°2 Cover attacco antina / Door fixing cover

Cache-vis pour pattes de fixation / Cover decorativas fijación

## UTENSILERIA • TOOLS • OUTILS • INSTRUMENTOS



## MANUTENZIONE • MAINTENANCE • ENTRETIEN • MANTENIMIENTO

Pulire con un panno morbido ed asciutto. Evitare l'uso di solventi e/o abrasivi.

Clean with a soft, dry cloth. Avoid using solvents or abrasive.

Nettoyez avec un chiffon sec et doux. N'utilisez pas aucun solvant ou produit abrasif.

Limpia con paño suave y seco. Evitar el uso de solventes y/o abrasivos.

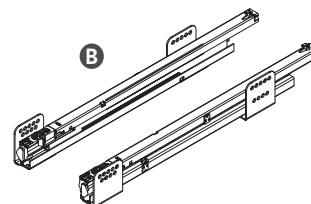
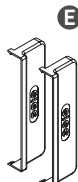
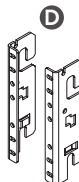
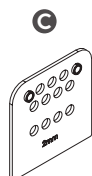
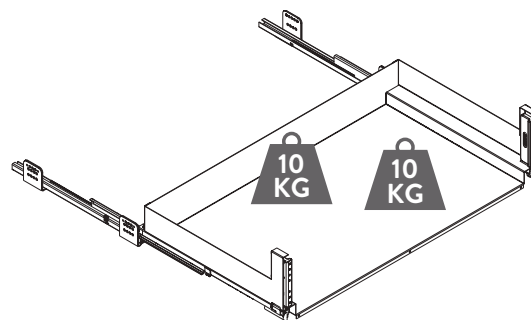
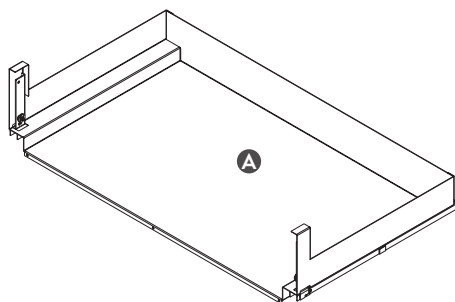
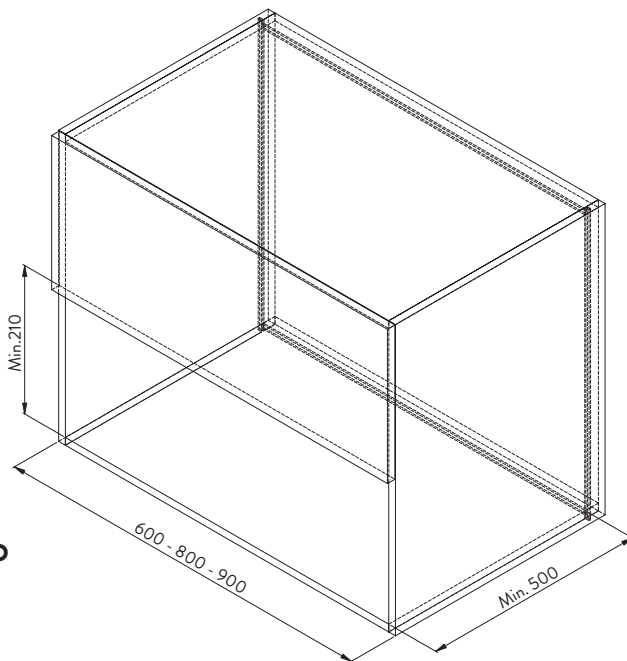

# 1

Per fianchi mobile di 18 o 19mm (1.1), procedere con il montaggio delle guide, (fase 2). Per fianchi mobile di 16 o 17mm (1.2), pre-installare gli spessori C sulle guide B, come mostrato, quindi procedere con il montaggio delle guide (fase 2).

For side thickness of 18 or 19mm (1.1), proceed with the slides installation (phase 2). For side thickness of 16 or 17mm (1.2), pre-assemble the spacers C on the slides B, as shown, then proceed with the slides installation (phase 2).

Pour meubles avec épaisseur 18mm ou 19mm, installer les coulisses (comme par point n.2) Pour meubles avec épaisseur 16mm ou 17mm, pre-assembler les épaisseurs C et ensuite installer les coulisses B (comme par point n.2).

Para costado del mueble de 18 o 19 mm (1.1), efectuar el montaje de las guías (fase 2). Para costado del mueble de 16 o 17 mm (1.2), instalar previamente los espesores C sobre las guías B, luego efectuar el montaje de las guías (fase 2).

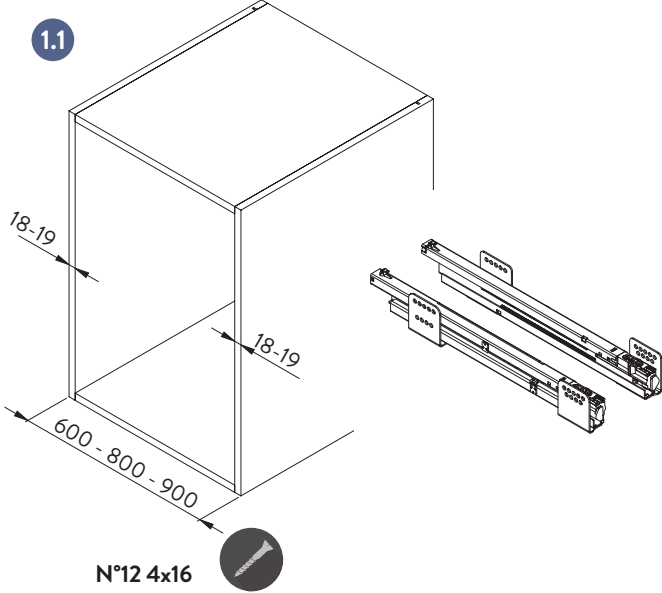

N°12 4x16

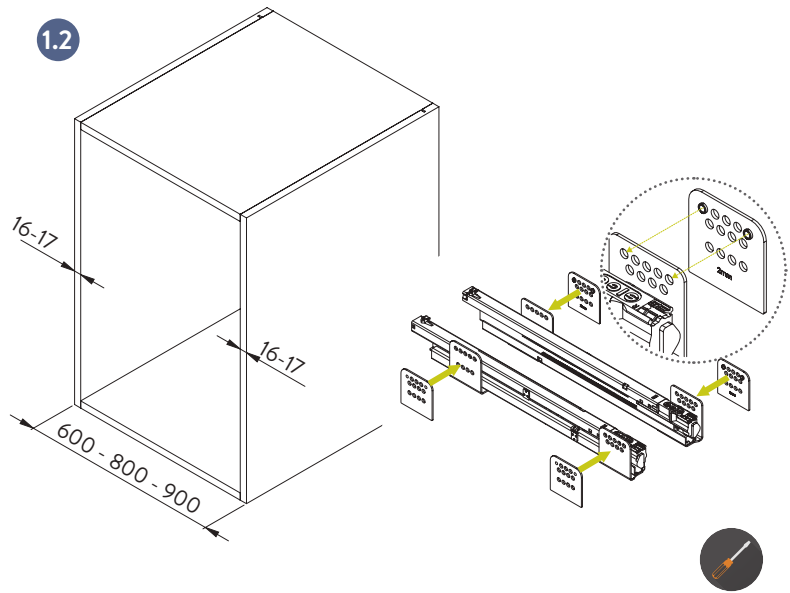

# 2

Posizionare le guide B rispettando le quote ed avvitare con le apposite viti. Place the slides B respecting the indicated measures and tighten with the appropriate screws.

Positionner les coulisses B en respectant les mesures indiquées et serrez les vis. Posicionar las guías B respetando las medidas y atornillar con sus debidos tornillos.

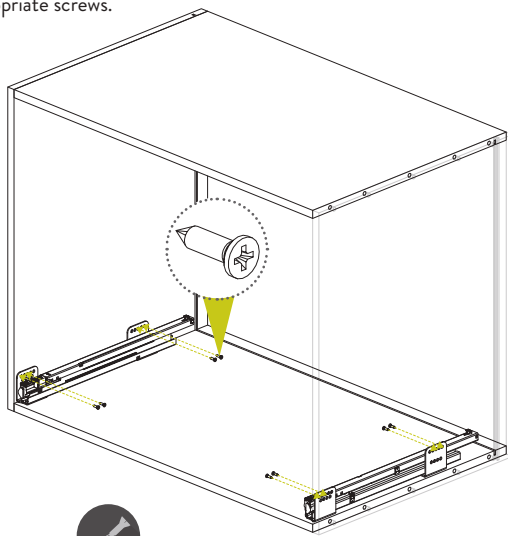

N°4 3,9x13

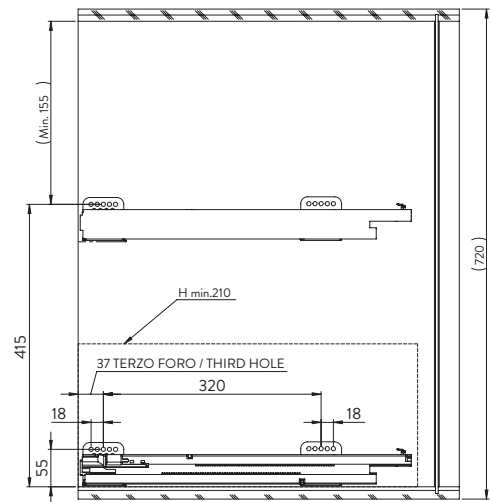

# 3

Fissare la coppia attacco antina D nell'anta, rispettando le quote. Assemble the door fixing brackets kit D to the door, according to the dimensions.

Fixer le kit de pattes de fixation D sur la porte du meuble en respectant les dimensions. Fijar el kit soportes de fijación de la puerta D en la puerta respetando las medidas.

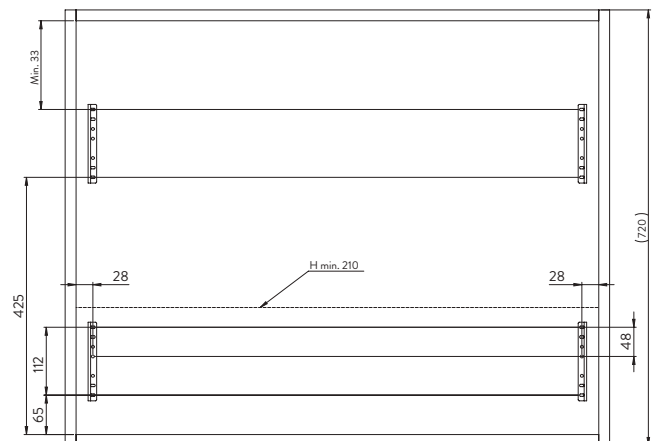
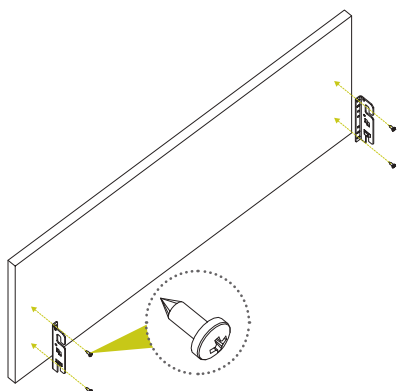

N°4 3,9x13



4

Estrarre le guide B ed agganciare i cesti A nelle guide.  
Pull out the slides B and hang the baskets A on the slides.

Sortir les coulisses B et monter les paniers A dans les coulisses.  
Sacar las guías B y colgar los cestos A en las guías.

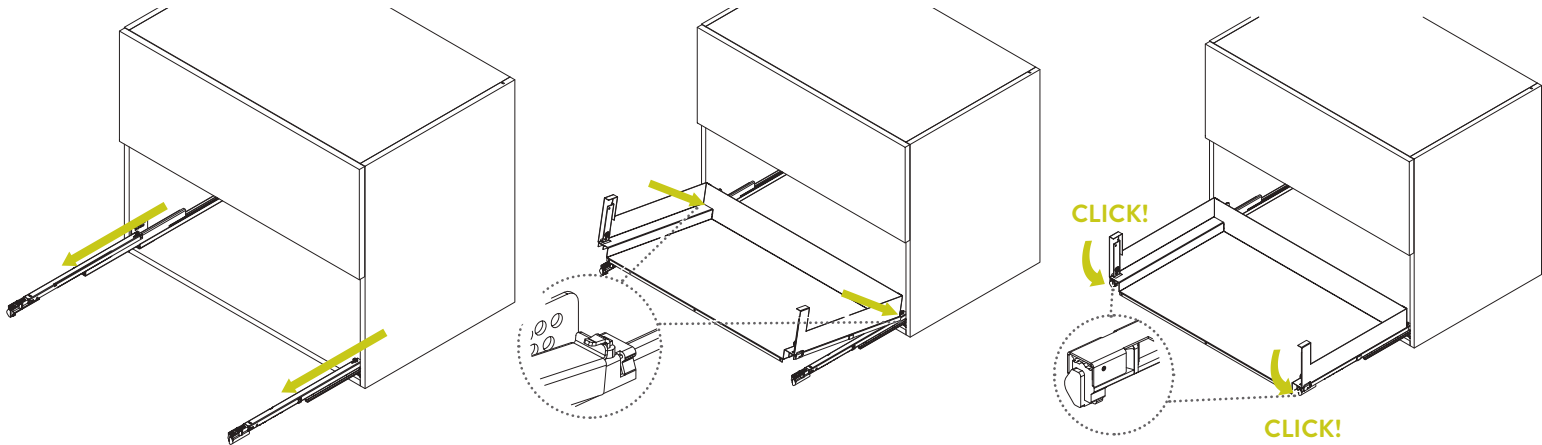

N°2 M6x10



5

Pre-montare le viti M6x10 con le rondelle e montare l'antina sul cesto A come mostrato.  
Pre-assemble the M6x10 screws and washers than mount the door on the basket A as shown.

Pré-assembler les vis M6x10 et les rondelles, monter selon indications la porte sur le panier A.  
Montar previamentee los tornillos M6x10 con las arandelas y montar la puerta sobre la cesta A como se indica.

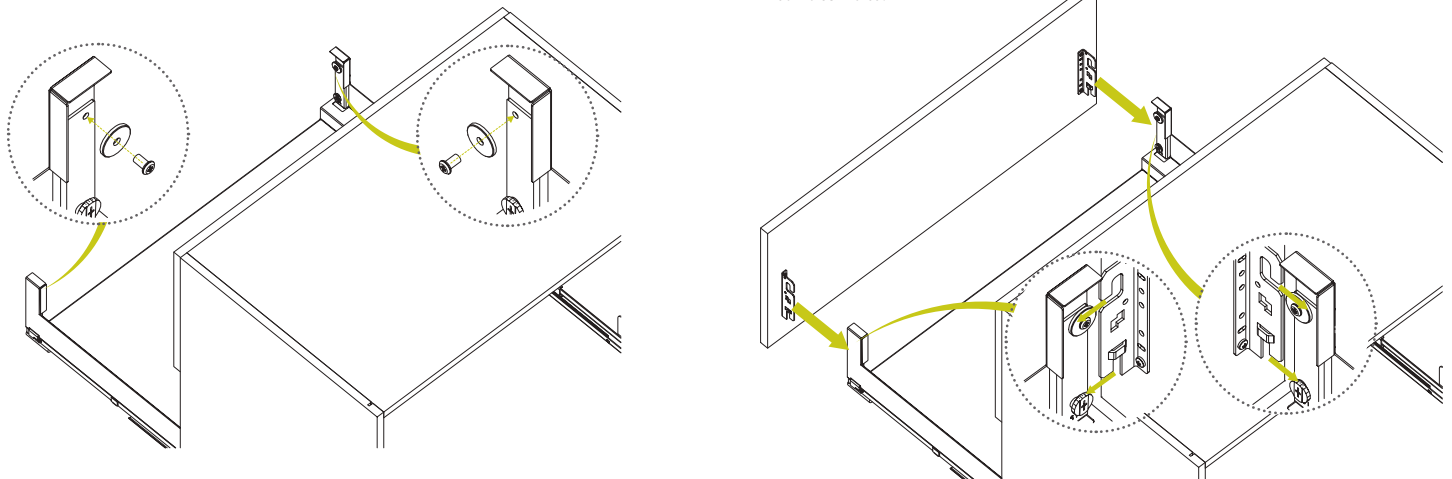

6

Allentare le due viti M6x10, regolare l'inclinazione avanti ed in dietro dell'anta.  
Loosen the two 6x10 screws, adjust the door inclination to the front or to the back.

Desserrer les deux vis 6x10, ajuster l'inclinaison de la porte à l'avant ou à l'arrière.

Aflojar los dos tornillos M6x10, Újste la inclinación de la puerta hacia delante o hacia ajustar.

7

Regolare l'antina su e giù tramite l'eccentrico, quindi serrare le due viti M6x10.  
Adjust the door up and down by turning the eccentric screw, than tighten the two M6x10 screws.

Ajuster la porte de haut en bas en tournant la vis excentrique, puis serrer les deux vis M6x10.

Ajustar la puerta hacia arriba y hacia abajo girando el tornillo excéntrico, apretando los dos tornillos M6x10.

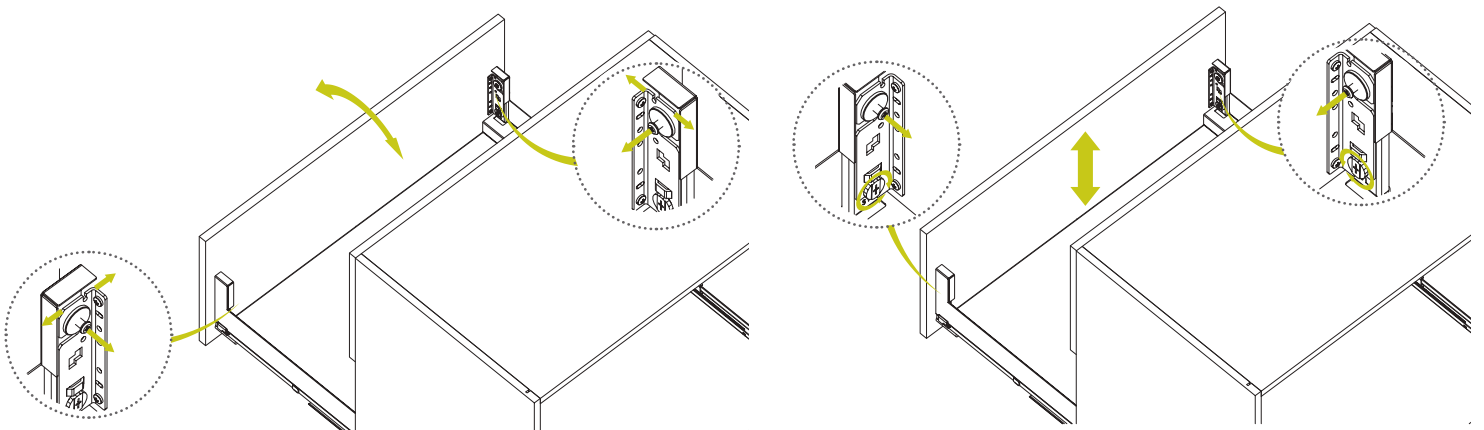

N°2 3,9x13



8

Allentare le viti presenti sulla staffa attacco antina D per regolare l'anta a destra e sinistra. quindi fissare tutto con le viti 3,9x13 come mostrato.

Desserrer les vis des pattes de fixation D pour régler la porte à droite et à gauche. Ensuite fixerle tout avec les vis 3,9x13 comme illustré.

Loosen the screws on the door fixing brackets D to adjust the door on the right and on the left. then fix everything with the 3,9x13 screws, as shown.

Aflojar los tornillos de los soportes de fijación de la puerta D para ajustar la puerta a derecha e izquierda. luego arreglar todo con los tornillos 3,9x13 como se muestra.

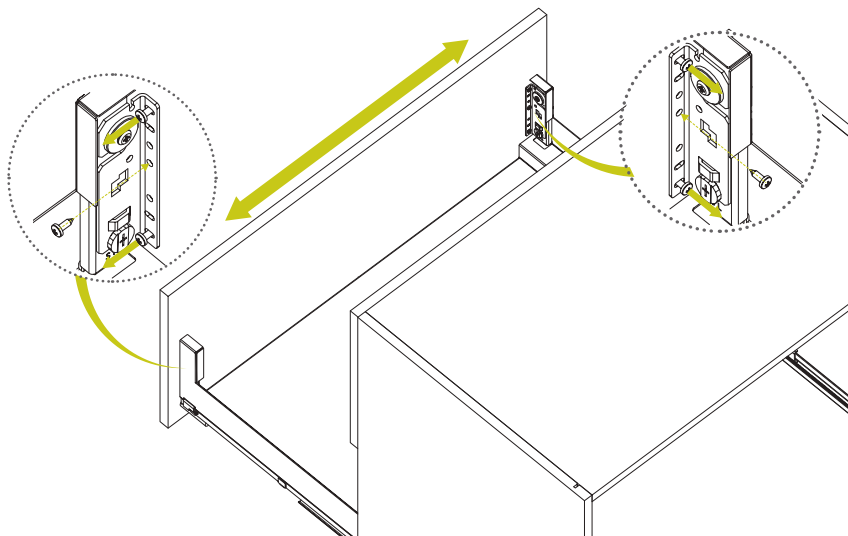

N°1 3,9x13



9

Fissare la parte inferiore del cesto all'antina.  
Fix the bottom of the basket to the door.  
Fixer le bas du panier à la porte.  
Fijar el fondo de la cesta a la puerta.

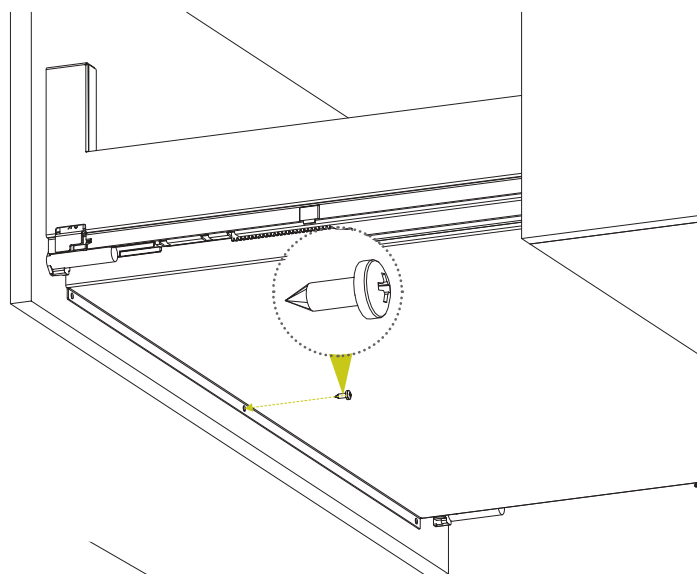

10

